

# Ruelco



**ESD Manual Valve**

**Model 1102**

Phone (504) 340-0055  
Fax (504) 340-0056

# ESD

## Manual Valve Model 1102

### FEATURES

- 316 stainless steel construction (models to N.A.C.E. MR0175 available).
- Large  $C_v$  factor provides a fast system response.
- May be used in pneumatic or hydraulic systems.
- No seals crossing ports.
- Easily repaired without removing valve from panel.

#### GENERAL DESCRIPTION:

The Ruelco 'ESD' manual valve has a simple and compact design. Its high flow rate and two way pull to open action makes it ideal for use in manual ESD systems and other control applications that require fast response time. The supply pressure acting on the unbalanced stem maintains the valve in the closed position. This prevents vibration or small pulling forces from accidentally opening the valve. Once pulled, the valve will stay in the open position until manually closed.

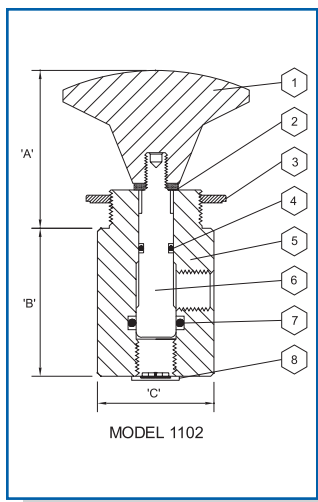

#### Dimensions Inch (MM)

'A' (Closed / Open)	1.66 / 2.16 (42.2 / 54.9)
'B'	1.59 (40.4)
'C'	1.25 (31.8)
Port Size	1/4" NPT
Panel Mount Hole	1.0 (25.4)
Max. Panel Thickness	.25 (6.4)
Weight	12 OZ. (340 GM.)

#### Specifications P.S.I. (BAR)

Valve Body Max. W.P.	150 (10.3)
Ambient Temp. Range	-20 to 250 deg. F -29 to 122 deg. C
$C_v$ Factor	1.8

### Parts List For ESD Manual Valve

Item	Qty.	Description	Material	Part No.
1A	1	Black Knob (optional)	Phenolic	ZO-200-001
1B	—	Red Knob	Phenolic	ZO-200-002
1C	—	Green Knob (optional)	Phenolic	ZO-200-003
2	1	Flat Washer	316 St. St.	WB-AKO-J43
3	1	Panel Mount Nut	316 St. St.	10-006-000
4*	1	Stem Seal	Viton	VO-010-75H
5	1	Body	316 St. St.	11-004 -000
6	1	Stem	316 St. St.	11-003-000
7*	1	Body Seal	Viton	VO-111-90H
8	1	Vent Screen (optional)	Plastic	ZO-100-000
9	—	Repair Kit	* Items	11-005-000

### Ordering Code: 1102 X 241 X X

BASE MODEL NUMBER

Standard Corrosive Service - (-)  
N.A.C.E. Option - N

B - Black Knob  
R - Red Knob  
G - Green Knob

0 - Without Vent Cover  
S - With Vent cover

# ESD Station

## Manual Pull To Shut-In Model 7002

### FEATURES

- 316 stainless steel construction (models to N.A.C.E. MR0175 available).
- Highly Visible Red Tag.
- Clamps to 1 1/2" dia. pipe (available for other pipe sizes upon request).
- Optional Pull Ring available in various sizes upon request.

#### GENERAL DESCRIPTION:

The Ruelco 'ESD' station is a compact, highly visible ESD station. It uses the Ruelco model 1102 high flow ESD valve. The Ruelco 'ESD' station uses a large red tag to increase visibility. It can be placed in any desired location by clamping the station to any 1-1/2" diameter handrail or any 1-1/2" diameter pipe. (Clamps for other pipe sizes available upon request).

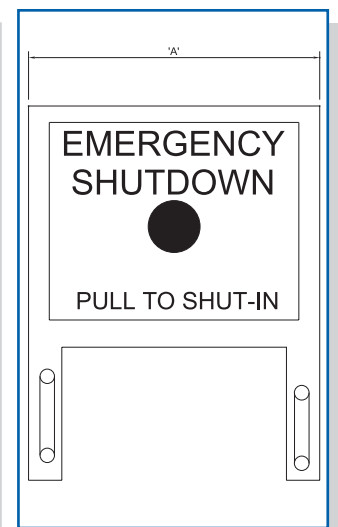
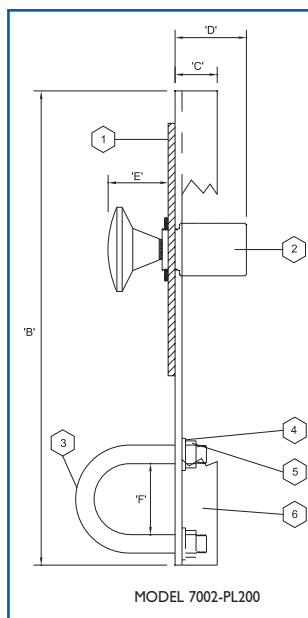

#### Dimensions Inch (MM)

'A'	8.75 (222.3)
'B'	11.25 (285.8)
'C'	1.0 (25.4)
'D'	1.66 (42.2)
'E' (Normal)	1.62 (41.1)
'E' (Pulled for ESD)	2.12 (53.8)
'F'	2.06 (52.32)

### Parts List For ESD Station

Item	Qty.	Description	Material	Part No.
1	1	Face Plate	Acrylic	70-001-000
2	1	ESD Valve	---	1102-2410R
3	2	U-Bolt	AISI 316 S.S.	TU-0C1204
4	2	Flat Washer	AISI 316 S.S.	WB-AKO-J43
5	2	Hex Nut	AISI 316 S.S.	TB-0C1-0A3
6	1	Support Bracket	AISI 316 S.S.	70-002-000

### Order Model 7002-PL200